

# G2 EMERGENCY FOR INDOOR USE



**JAYKAL**

PROJECT NAME:

**JAYKAL LED SOLUTIONS, INC.**

[www.jaykal.net](http://www.jaykal.net)

PROJECT NOTES:

21499 Baltimore Ave.

Georgetown, DE 19947

(P) 302-295-0015

(F) 302-295-0016

## DESCRIPTION

Provides up to 90 minutes of backup power for fixtures with one LED driver in emergency lighting applications.

## FEATURES

- ◆ Listed to UL924 and tested to CSA C22.2 NO.141
- ◆ Field or factory installation
- ◆ Low energy consumption CEC compliance
- ◆ Constant output power
- ◆ Self-testing
- ◆ Battery : Over Temperature Protection / Over Charge Protection / Over Discharge Protection

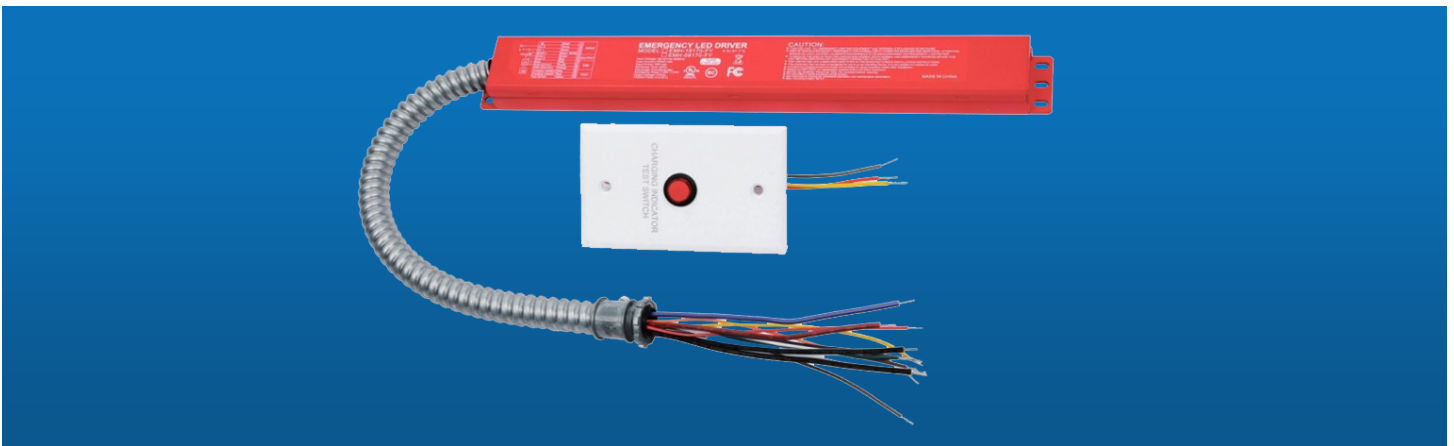

Revised 6/14/23

*Specifications are typical values and may change without notification*

**efficiency. illuminated.**

# G2 EMERGENCY FOR INDOOR USE



**JAYKAL**

## SPECIFICATIONS TABLE

<b>INPUT VOLTAGE</b>	100-347VAC 50/60hz	<b>OUTPUT WATTAGE</b>	8W/18W	<b>WARRANTY</b>	5 Years
<b>RECHARGE POWER</b>	10W	<b>INPUT CURRENT</b>	150mA max	<b>PROTECTION</b>	IP20
<b>OUTPUT VOLTAGE</b>	170 VDC	<b>WEIGHT</b>	0.9 kg	<b>RECHARGE TIME</b>	24Hours
<b>BATTERY TYPE</b>	Li-ion	<b>ENVIRONMENT</b>	Indoor/Damp Locations	<b>HOUSING MATERIAL</b>	Sheet Metal
<b>EMERGENCY RUN TIME</b>	90 Minutes	<b>AMBIENT TEMP.</b>	0°C — 50°C		
<b>HOUSING COLOR</b>	RED	<b>DIMENSIONS</b>	L 13.59" X W 1.54" X H 0.99"		

## DIMENSIONS

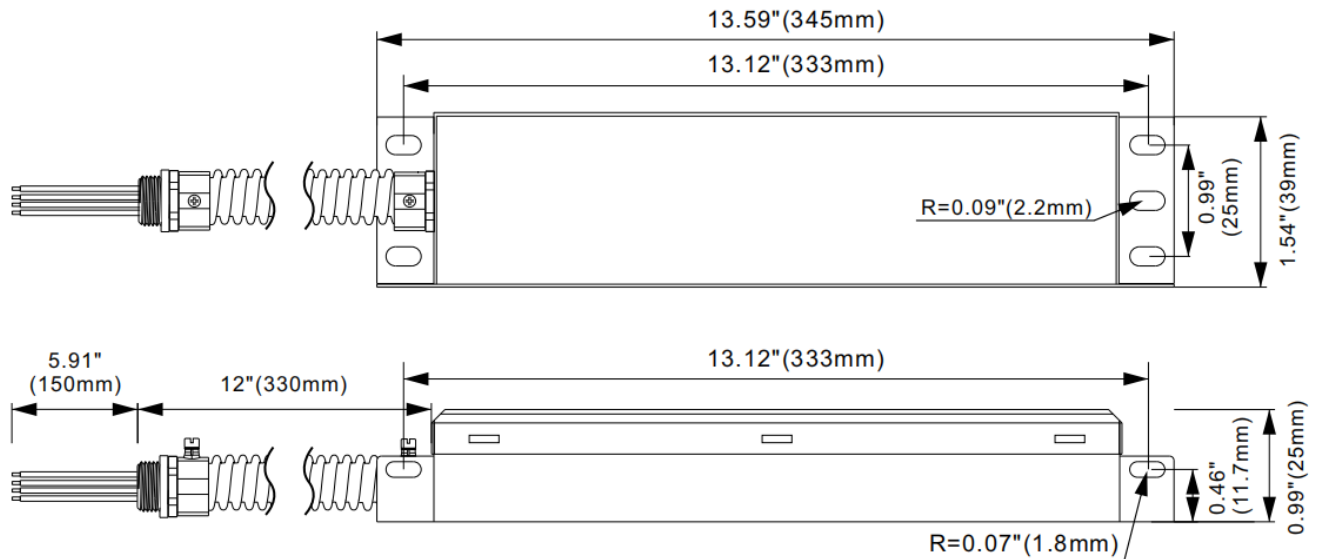

## ORDERING INFORMATION

JLS6810D-G2EM-08170-HY

MODEL	-	WATTAGE	-	VOLTAGE
JLS6810D-G2EM		08170 = 8W 170VDC 18170 = 18W 170VDC		HY = 347VAC

*Specifications are typical values and may change without notification*

**efficiency. illuminated.**

# G2 EMERGENCY FOR INDOOR USE



JAYKAL

## WIRING DIAGRAM

### A : FOR LED FIXTURE POWER $\leq$ EMERGENCY LED DRIVER

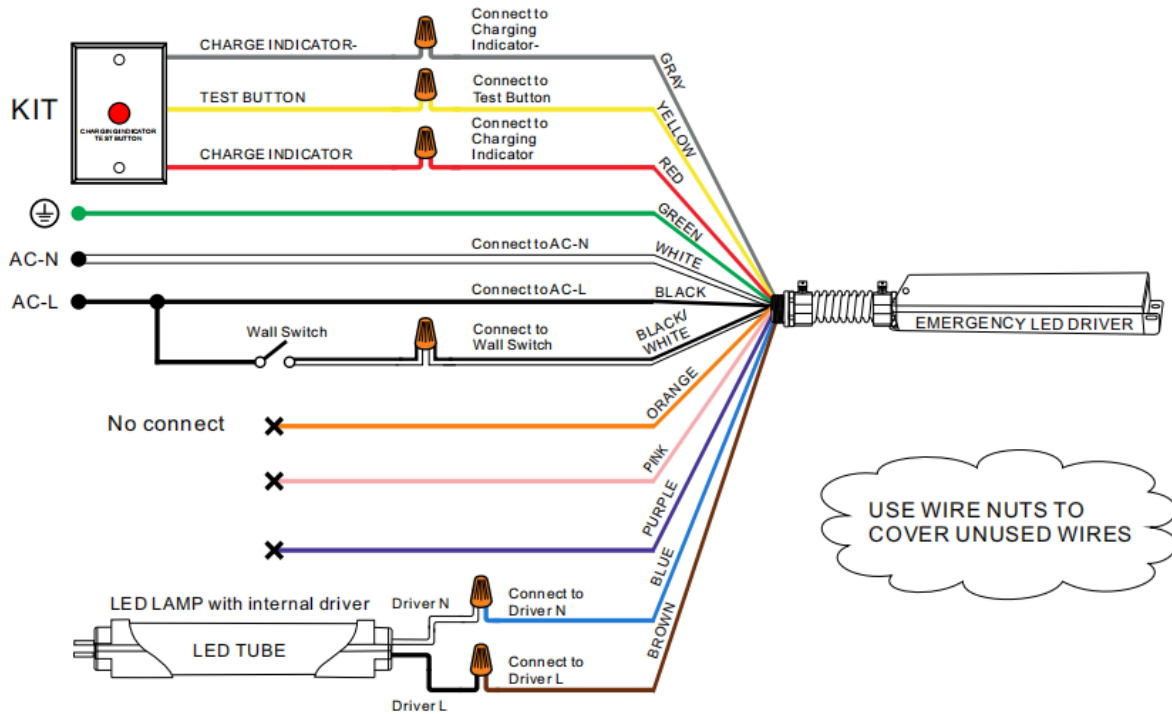

### B : FOR LED FIXTURE WITH DIMMING WIRES

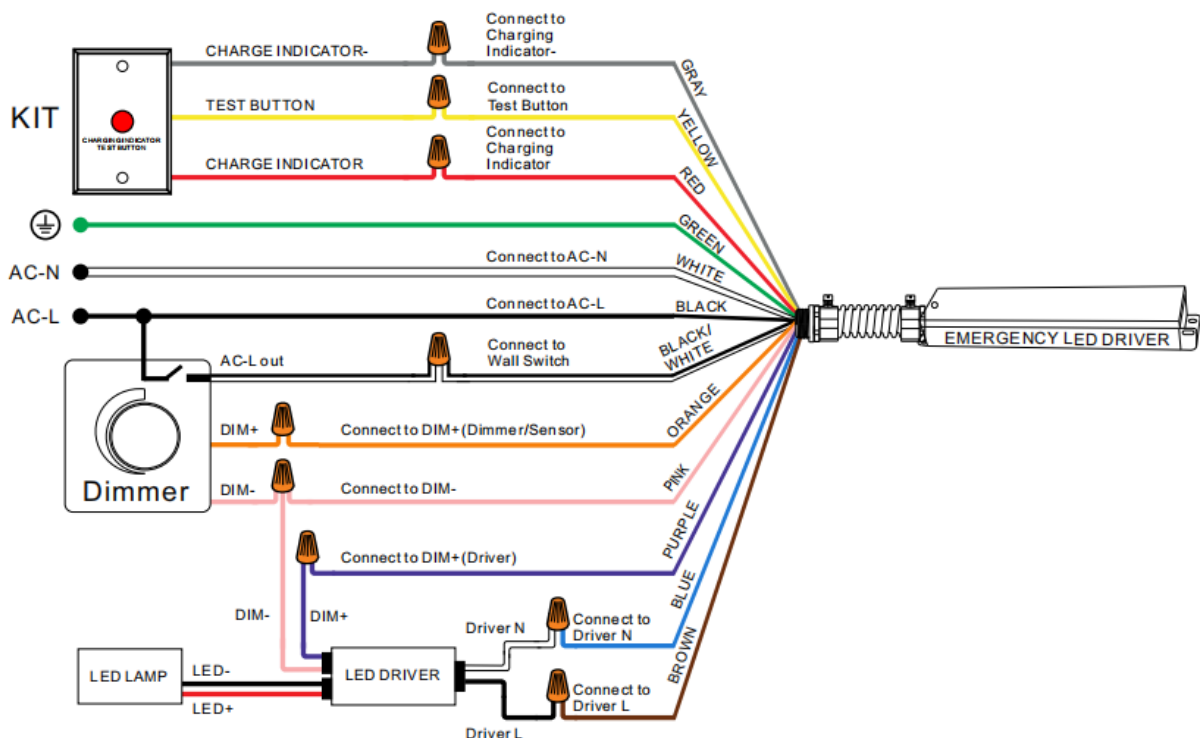

Specifications are typical values and may change without notification

efficiency. illuminated.